



WAIROA DISTRICT COUNCIL

☎ +64 6 838 7309

☎ +64 6 838 8874

✉ consents@wairoadc.govt.nz

🌐 www.wairoadc.govt.nz

📦 PO Box 54, Wairoa 4160, Hawke's Bay

🏠 Coronation Square, Queen Street, Wairoa

INFORMATION SHEET 20

APPLYING FOR A FIREPLACE CONSENT

What you need to know?

Rules governing fireplaces are designed to keep people safe and to protect the environment. Fireplaces are one of the oldest ways of heating homes but there are significant safety issues associated with their installation, so rules exist to minimise potential risk to the occupant's.

New and replacement freestanding and inbuilt fireplaces always require a Building Consent before installing any fireplace. This helps to ensure the fireplace meets all safety standards.

All wood burners installed on properties less than 2 hectares in size must meet requirements as set out in the wood burner standards which are part of the National Environmental Standards for Air Quality.

To check if your fire model is approved please follow this link <https://www.ecan.govt.nz/data/authorised-burners/>

Open fires, multi-fuel burners, pellet burners and wood-burning cooking stoves are not included in the definition of wood burner so are exempt from the requirement for clean air approval.

If you are planning to install a new residential fireplace, you need to lodge an online Building Consent. You can apply online at <https://www.wairoadc.govt.nz/assets/Document-Library/Forms/Building/Application-For-Building-Consent.pdf>

A paper version of the Building Consent application form is also available at the Wairoa District Council, please be aware that if you wish to manually lodge a building consents over the counter, it will incur an additional \$270 manual lodgement fee.

What will a Fireplace Consent cost me?

A Fireplace Consent is relatively straight forward and has set Consent fees (see our website for these fees). Fees will depend on whether you are installing an In-Built or Freestanding Fireplace and the location of the install.

Range of Fees for a Fireplace Consent \$590 - 860 (Flat Fee)

You will need the following documents:

- Certificate of Title / or a Rates Bill – for Proof of ownership
- Written Permission from Owner (if an anyone acting on owner's behalf)
- Make and Model of the Fireplace and Flue Kit
- Fireplace installation manual
- Flue Kit installation manual
- Full House Floor Plan
- Roof and Ceiling penetration diagrams
- Flashing Details

Please note additional information may be required as each consent is processed on a case by case basis.



WAIROA DISTRICT COUNCIL

☎ +64 6 838 7309

☎ +64 6 838 8874

✉ consents@wairoadc.govt.nz

🌐 www.wairoadc.govt.nz

📮 PO Box 54, Wairoa 4160, Hawke's Bay

🏠 Coronation Square, Queen Street, Wairoa



INFORMATION SHEET 20

Installing 2nd hand fires?

If you are wanting to install a 2nd hand fireplace it must be checked by a suitably qualified person, usually a Certifying Plumber who will check the fireplace to make sure it still in good working order and has a compliant emission certificate. Their report on the fireplace will need to be supplied as part of the application documents. Please note that a new flue & flashings will be required.

Full Floor Plan



-  General placement of Smoke Detector
-  Fireplace location
-  Recommended placement of Smoke Detectors

Smoke alarms must be installed within 3m of all bedroom doors or in each bedroom by law.

Note: All clearances need to be indicated if fireplace is installed in close proximity to combustible materials other than what's stated in the installer manual.



WAIROA DISTRICT COUNCIL

☎ +64 6 838 7309

☎ +64 6 838 8874

✉ consents@wairoadc.govt.nz

🌐 www.wairoadc.govt.nz

📮 PO Box 54, Wairoa 4160, Hawke's Bay

🏠 Coronation Square, Queen Street, Wairoa

INFORMATION SHEET 20

SMOKE DETECTORS

No matter how minor the work carried out on a dwelling, if it requires a Building Consent, the whole dwelling must be upgraded with smoke detectors in order to comply with the Building Code.

Smoke Detectors Must Be Located:

- On the escape routes on all levels within the dwelling.
- Located in either every sleeping space or within 3 metres of every sleeping space door, so that the alarm is audible to occupants on the other side of a closed door.

Smoke alarms are to be installed on or near the ceiling, in accordance with the manufacturer's instructions.

The smoke detectors may be battery powered and are not required to be interconnected. In addition, they must provide a hush facility with a minimum duration of 60 seconds.

Placement of Smoke Detectors

These 5 examples below identify Dead Air Spaces. The placement of the smoke detectors are paramount to the device operating as per its intended purpose.

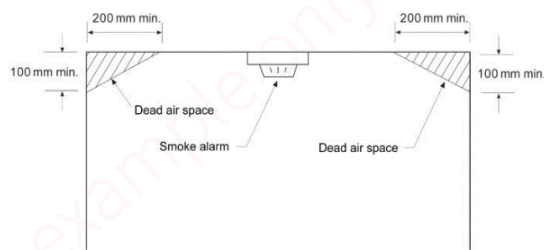

(a) Ceiling mount with exposed airflow

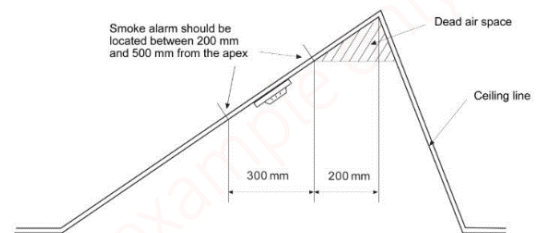

(b) Ceiling mount – sloping ceiling



WAIROA DISTRICT COUNCIL

☎ +64 6 838 7309

☎ +64 6 838 8874

✉ consents@wairoadc.govt.nz

🌐 www.wairoadc.govt.nz

📮 PO Box 54, Wairoa 4160, Hawke's Bay

🏠 Coronation Square, Queen Street, Wairoa

INFORMATION SHEET 20

Placement examples cont

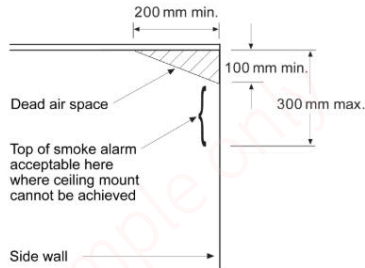

(c) Ceiling mount not available

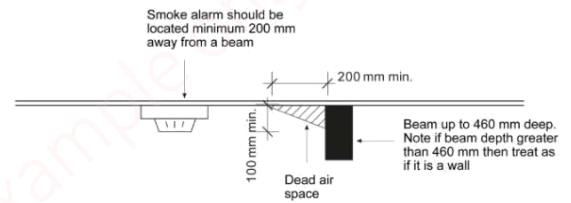

(d) Exposed beams (or other ceiling obstructions)

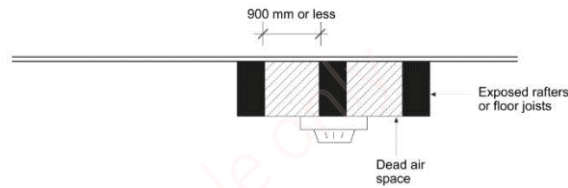

(e) Exposed rafters or floor joists



CLEARANCE DETAIL GUIDANCE

Hearth Clearances

The hearth is the fireproof area directly in front of a fireplace and must provide protection of the floor from the physical hazards of falling embers, as well as downward heat radiation from the fireplace.

The fixing and materials of the hearth must be followed as required by the manufacturer.

Details of the hearth should include its construction materials (ceramic tiles, concrete, brick, etc) and its size dimensions.

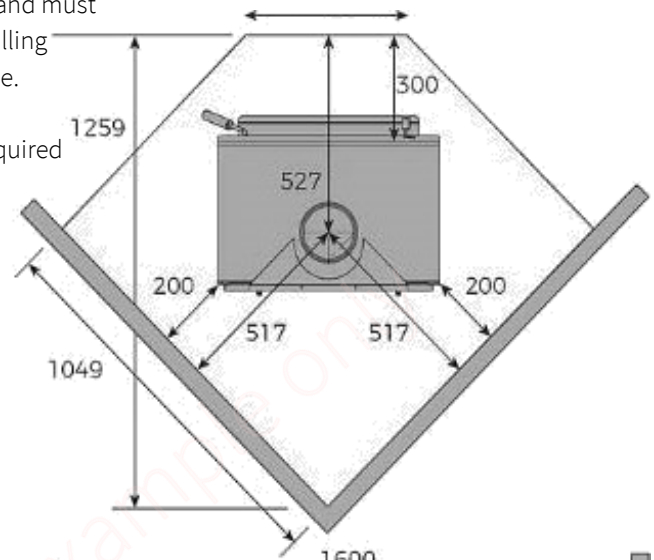

Wall Clearance

The space between the appliance and the wall must take into account both short and long-term temperature effects. The distance may only be reduced if a flue screen or a heat shield is used between the appliance and the wall.

Materials for heat screens may include sheet metal, bricks, suitable mineral board or a test combination of these three.

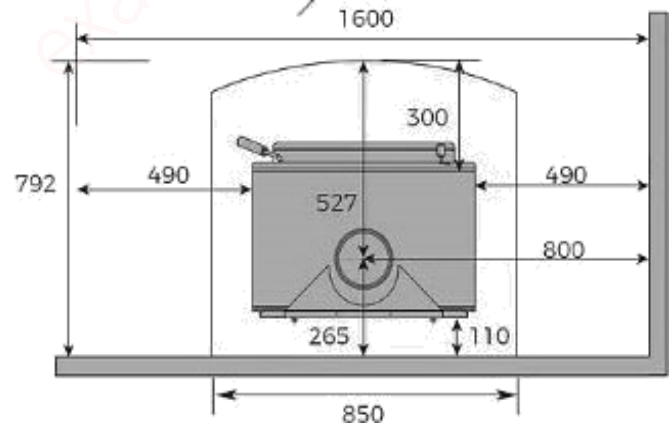

There must be a gap at the top and bottom of the shield to allow air to circulate behind it.

Manufacturer's specifications MUST be adhered to.

Ceiling Flue Type



WAIROA DISTRICT COUNCIL

☎ +64 6 838 7309

☎ +64 6 838 8874

✉ consents@wairoadc.govt.nz

🌐 www.wairoadc.govt.nz

📮 PO Box 54, Wairoa 4160, Hawke's Bay

🏠 Coronation Square, Queen Street, Wairoa

INFORMATION SHEET 20

Please indicate the specific flue installation model and method as demonstrated in the examples below to remove confusion about which type of flue is being proposed.

The main flue and flue shields passing through the ceiling and floor must be clear of all ceiling and roof timbers. Structural members (for example beams, rafters, or trusses) must NOT be cut to allow penetration of the flue or flue shields.

Penetration support MUST be achieved in both the ceiling joists (*flue support*) and rafters (*roofing iron support*), we always request photo evidence of this.

Detailed below are the more common installation methods for installing Metro ECO Flue Systems. To ensure a safe and efficient installation, this flue system must be installed as detailed below by either a registered installer, or someone competent in installing solid fuel appliances.

Single Storey Installations

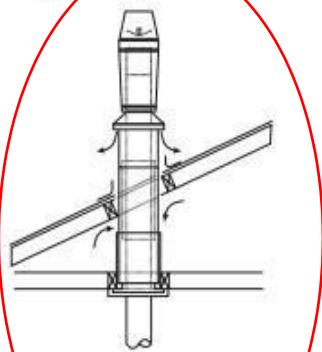

Flat Cavity Ceiling

ECO Flue Kit only required as air is drawn into the flue system direct from the ceiling cavity.

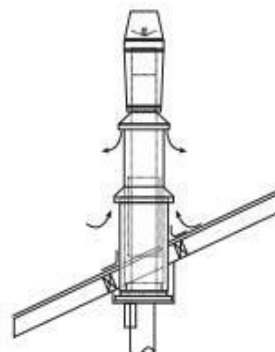

Sloping Ceiling

Both the ECO Flue Kit and ECO Option Kit are required to enable air to be drawn from outside the home.

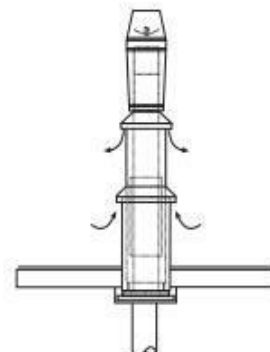

Flat Ceiling/Roof

Requires both ECO Flue Kit and ECO Option Kit as per sloping ceiling unless a vented ceiling cavity exists.

Two Storey Installations

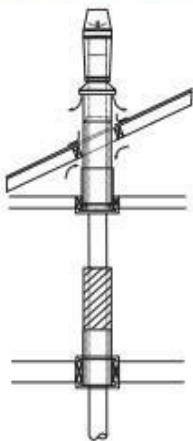

2nd Floor - Exposed Flue pipe

Requires an ECO Flue Kit only with additional lengths of flue pipe.

Additional components below are not supplied by Metrofires but are also required for this installation*

- A floor penetration kit
- 1x 1200mm long mesh/screen

*In accordance with AS/NZS2918:2001

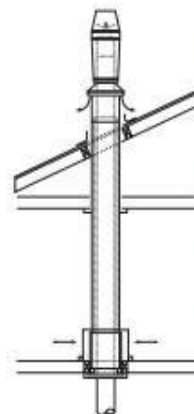

2nd Floor - Enclosed Flue pipe

Requires an ECO Flue Kit only with additional lengths of flue pipe.

Additional components below are not supplied by Metrofires but are also required for this installation*

- 200mm & 250mm inner/outer combination liners.
- 2nd floor vent cover and an additional ceiling plate with a 250mm diameter hole

*In accordance with AS/NZS2918:2001



WAIROA DISTRICT COUNCIL

☎ +64 6 838 7309

☎ +64 6 838 8874

✉ consents@wairoadc.govt.nz

🌐 www.wairoadc.govt.nz

📮 PO Box 54, Wairoa 4160, Hawke's Bay

🏠 Coronation Square, Queen Street, Wairoa

INFORMATION SHEET 20

Flue Distances from Roof Ridge

The flue height above the roof needs to meet the height requirements set out in AS / NZS 2918:2001 - Domestic solid fuel burning appliances – Installation (example below).

These requirements ensures the fireplace is able to operate correctly, allowing sufficient ventilation limiting the back draughts and prevents flue gases from causing damage to the roof.

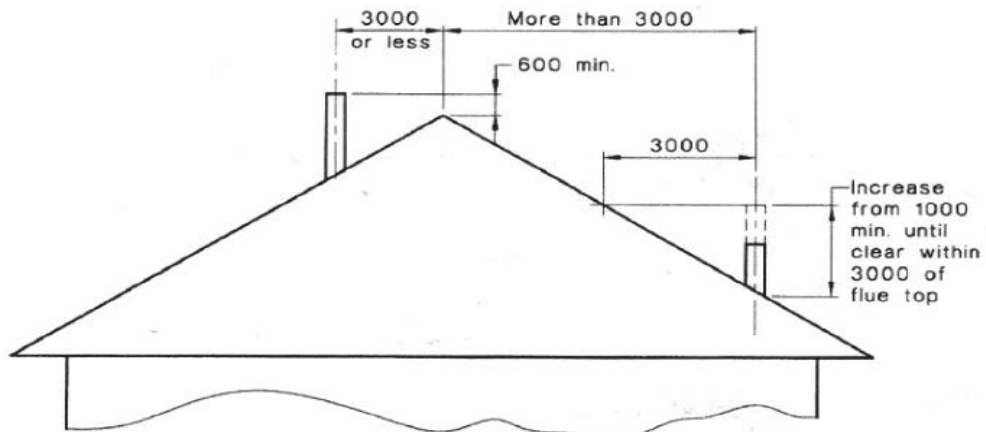
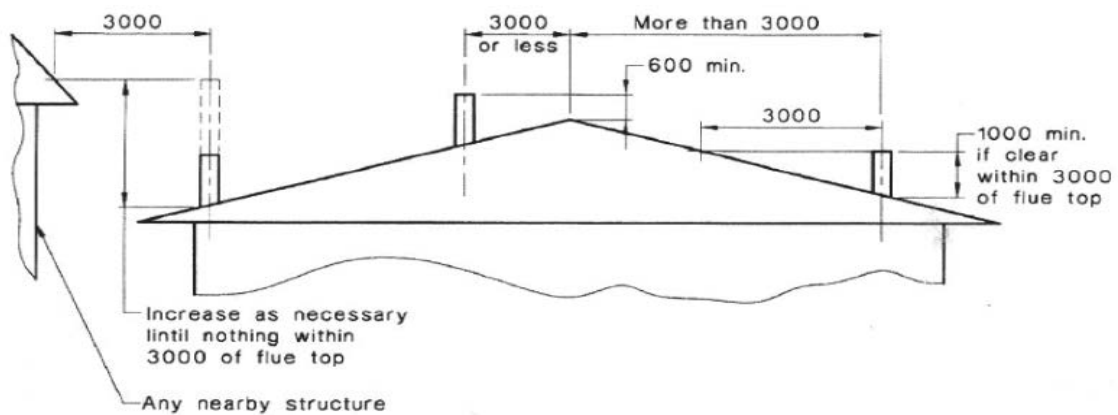

DIMENSIONS IN MILLIMETRES

INFORMATION SHEET 20

Flashing Details

When a penetration for a pipe or flue system is made, Soaker Flashing along with a Rubber Boot Dektite must be installed to ensure that the building achieves to at least the same standard of weather tightness (no leaks) as before the work was undertaken

The following examples demonstrate the minimum requirements to comply with E2/AS1.

Table.7 of E2/AS1 indicates Y – A minimum of two full crests finishing in the third crest is needed to prevent any rainwater accessing the flue penetration.

NOTE: (1) Suitable for pipes from 86 mm to 500 mm diameter.
(2) Suitable only for roof pitches of 10° or more.

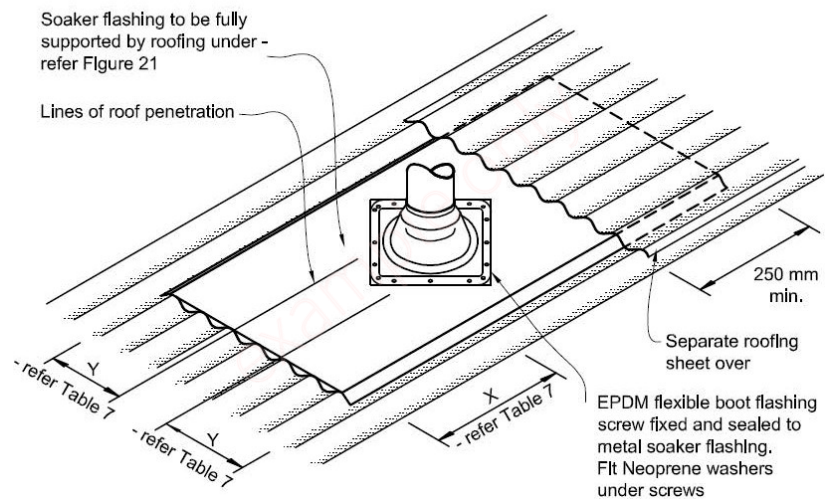

EPDM Rubber Boot Dektites

When installing an EPDM Rubber Boot Dektite, there are certain rules that need to be adhered to (as per the example).

Rubber boots have been engineered to accommodate the extreme movement in pipes due to temperature and weather, while maintaining a watertight seal.

The materials for rubber flashing boots are engineered to provide very long-term performance.

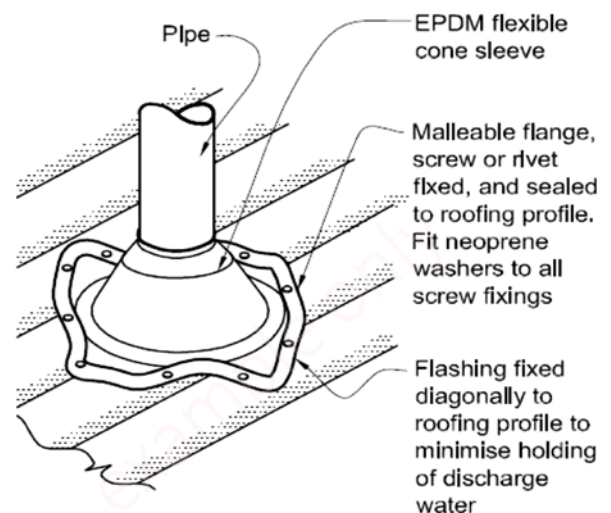

NOTE:

- (1) Max. roof pitch for this flashing 45°, minimum pitch 10° if base of flange covers one or more complete troughs.
- (2) For pipes up to 85 mm diameter.



WAIROA DISTRICT COUNCIL

☎ +64 6 838 7309

☎ +64 6 838 8874

✉ consents@wairoadc.govt.nz

🌐 www.wairoadc.govt.nz

📮 PO Box 54, Wairoa 4160, Hawke's Bay

🏠 Coronation Square, Queen Street, Wairoa

INFORMATION SHEET 20

Penetration Support

When the roofing iron is cut to allow for the flue penetration the iron around the penetration weakens.

The penetration support as shown in the example ensures that the iron is supported and that weather tightness is not compromised by sagging roofing iron

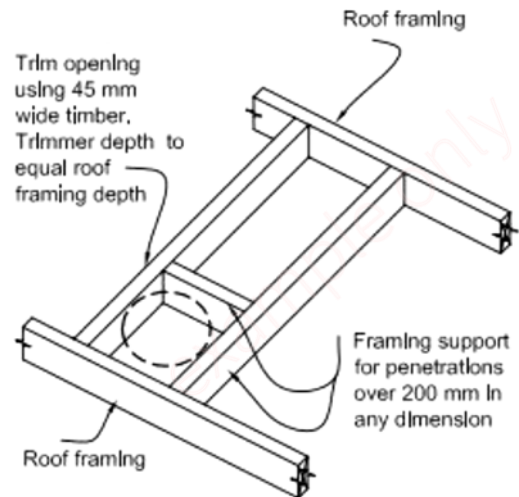



WAIROA DISTRICT COUNCIL

☎ +64 6 838 7309

☎ +64 6 838 8874

✉ consents@wairoadc.govt.nz

🌐 www.wairoadc.govt.nz

📮 PO Box 54, Wairoa 4160, Hawke's Bay

🏠 Coronation Square, Queen Street, Wairoa

INFORMATION SHEET 20

FLASHING/ ROOF COMPATIBLE MATERIALS

Not all Roofing materials are compatible.

The diagram below should be considered when selecting a material for your soaker flashing if material is different from the roofing iron.

If the two materials are incompatible, this is likely to result in corrosion of one or both of the materials, having a negative impact on the stability and durability of roof.

Run-off from (upper)	Lower material	Aluminium	Pre-painted steel	AZ coated steel	Zinc or zinc coated steel	Pre-painted AZ steel	Copper*/brass	Stainless steel	Lead*	Plastic/glass	Concrete/plaster wet	Concrete/plaster dry	Wet timber	Steel	Cedar*	Butyl rubber (wet)
		Aluminium	Contact	✓	✓	✓	✓	✗	?	✗	✓	✗	?	✗	?	✗
	Run onto	✓	✓	✗	✗	✓	✓	✓	✓	✓	✓	✓	✓	✓	✓	✓
Pre-painted Aluminium	Contact	✓	✓	?	?	✗	✗	✗	✓	?	?	✗	✗	✗	✗	✗
	Run onto	✓	✓	✗	✗	✓	✓	✓	✓	✓	✓	✓	✓	✓	✓	✓
AZ coated steel Zincalume*	Contact	✓	✓	✓	✓	✗	✗	✗	✓	✗	✓	✗	?	✗	✗	✗
	Run onto	✓	✓	✗	✗	✓	✓	✓	✓	✓	✓	✓	✓	✓	✓	✓
Zinc or Zinc coated steel (galvanised - Z)	Contact	✓	✓	✓	✓	✗	?	✓	✓	✓	✓	✗	✗	✗	✗	✗
	Run onto	✓	✓	✓	✓	✓	✓	✓	✓	✓	✓	✓	✓	✓	✓	✓
Pre-painted AZ steel	Contact	✓	✓	✓	✓	✗	?	✗	✓	✗	✗	✗	?	✗	✗	✗
	Run onto	✓	✓	✗	✗	✓	✓	✓	✓	✓	✓	✓	✓	✓	✓	✓
Copper*/brass	Contact	✗	✗	✗	✗	✗	✓	?	✓	✓	✓	✓	✓	✗	✓	✓
	Run onto	✗	✗	✗	✗	✗	✓	?	✓	✓	✓	✓	✓	✗	✓	✓
Stainless steel	Contact	?	✗	✗	?	✗	✓	✓	✓	✓	✓	✓	✓	✗	✓	✓
	Run onto	✓	✓	✓	✗	✓	✓	✓	✓	✓	✓	✓	✓	✓	✓	✓
Lead*	Contact	✗	✗	✗	✗	✗	?	✓	✓	✓	✓	✓	✗	?	✓	✓
	Run onto	?	✗	✗	✓	✗	✓	✓	✗	✓	✓	✓	✓	?	✓	✓
Plastic/glass	Contact	✓	✓	✓	✓	✓	✓	✓	✓	✓	✓	✓	✓	✓	✓	✓
	Run onto	✓	✓	✓	✗	✓	✓	✓	✓	✓	✓	✓	✓	✓	✓	✓
Concrete/plaster wet	Contact	✗	✗	✗	?	✗	✓	✓	✓	✓	✓	✓	✓	✗	✓	✓
	Run onto	?	✓	✗	?	?	✓	✓	✓	✓	✓	✓	✓	✓	✓	✓
Concrete/plaster dry	Contact	?	?	?	✓	✓	✓	✓	✓	✓	✓	✓	?	✓	✓	✓
	Run onto	n/a	n/a	n/a	n/a	n/a	n/a	n/a	n/a	n/a	n/a	n/a	n/a	n/a	n/a	n/a
Wet timber	Contact	✗	✗	?	✗	✗	?	?	✗	✓	✓	✓	✓	✗	✓	✓
	Run onto	?	✗	?	✗	✗	?	?	✗	✓	✓	✓	✓	?	✓	✓
Steel	Contact	?	✗	?	✗	?	✗	✗	?	✓	?	✓	✗	✗	✗	✗
	Run onto	✓	✓	✗	✗	✓	✓	✓	✓	✓	✓	✓	✓	✓	✓	✓
Cedar*	Contact	✗	✗	✗	✗	✗	✓	✓	✓	✓	✓	✓	✓	✓	✓	✓
	Run onto	✓	✓	✓	✓	✓	✓	✓	✓	✓	✓	✓	✓	✓	✓	✓
Butyl rubber (wet)	Contact	✗	✗	✗	✗	✗	✓	✓	✓	✓	✓	✓	✓	✓	✓	✓
	Run onto	?	?	✗	?	?	✓	✓	✓	✓	✓	✓	✓	✓	✓	✓

✓	Suitable
✗	Not suitable
?	May need separation. Use with caution in severe or moist environments
*	May cause staining but not corrosion

NOTE: Run off and contact effects may vary according to the relative size/area of the two materials.



WAIROA DISTRICT COUNCIL

☎ +64 6 838 7309

☎ +64 6 838 8874

✉ consents@wairoadc.govt.nz

🌐 www.wairoadc.govt.nz

📮 PO Box 54, Wairoa 4160, Hawke's Bay

🏠 Coronation Square, Queen Street, Wairoa

INFORMATION SHEET 20

CORROSION ZONES

When selecting appropriate materials, the overall environment in the location of the intended structure requires consideration. A structure situated in an aggressive environment will require a higher standard of corrosion protection than one in a benign environment. The environment can have an adverse effect on the metal fixings and fastenings and to a lesser extent on the timber and concrete.

Exposure Zone Description

ZONE B: Low

Inland areas with little risk from wind-blown sea-spray deposits.

ZONE C: Medium

Inland coastal areas with medium risk from wind-blown sea-spray salt deposit. This zone covers mainly coastal areas with relatively low salinity. The extent of the affected area varies significantly with factors such as winds, topography and vegetation.

ZONE D: High

Coastal areas with high risk of wind-blown sea-spray salt deposits. This is defined as within 500m of the sea including harbours, 100m from tidal estuaries and sheltered inlets, and otherwise as shown in the diagram





WAIROA DISTRICT COUNCIL

☎ +64 6 838 7309

☎ +64 6 838 8874

✉ consents@wairoadc.govt.nz

🌐 www.wairoadc.govt.nz

📮 PO Box 54, Wairoa 4160, Hawke's Bay

🏠 Coronation Square, Queen Street, Wairoa

INFORMATION SHEET 20

ADDITIONAL INFORMATION

Wetback Installation

If the fireplace has a wetback which is to be connected to a hot water system, you are required to have the work carried out by a Certifying Plumber.

A valve train layout, indicating the sequence and type of valves, will need to be supplied when installing a wetback. Please see your plumber for further assistance on this aspect of the application.

The valve train layout below is intended as a guide only and demonstrates one possible solution of a system that will comply with the building code.

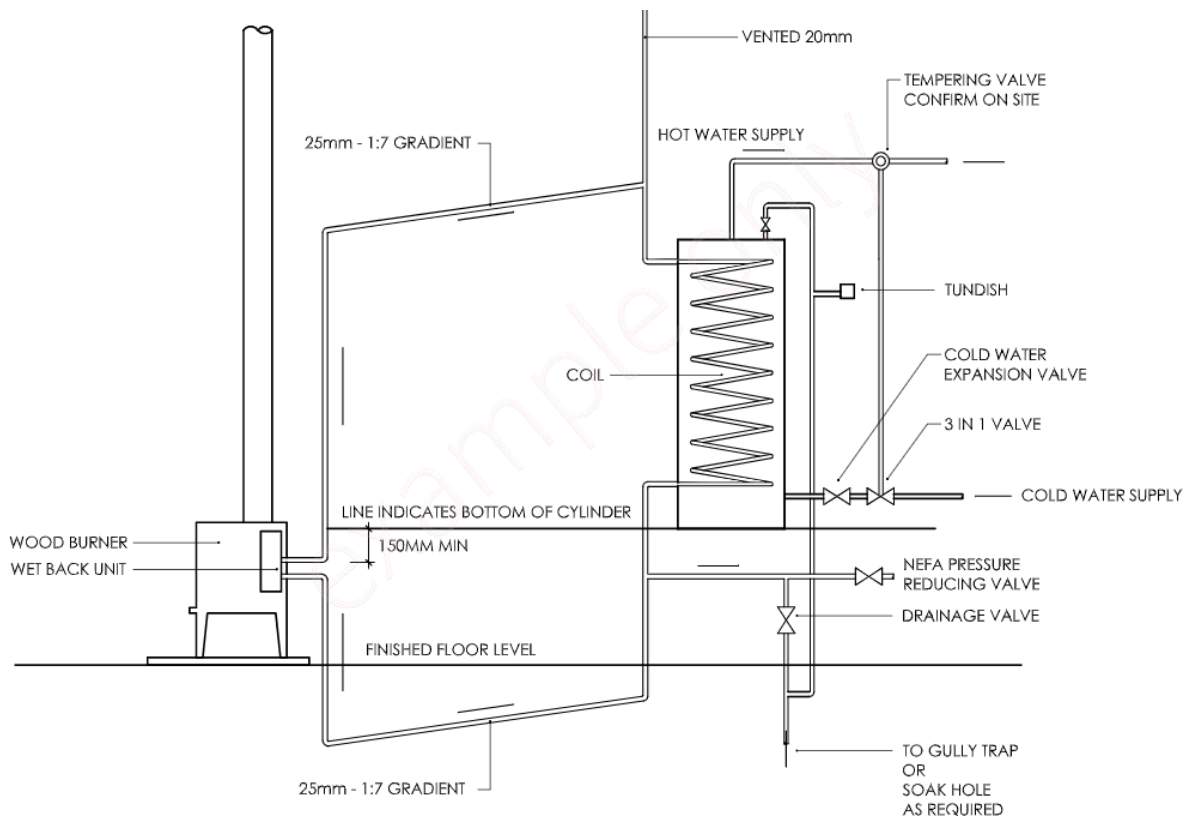



WAIROA DISTRICT COUNCIL

☎ +64 6 838 7309

☎ +64 6 838 8874

✉ consents@wairoadc.govt.nz

🌐 www.wairoadc.govt.nz

📮 PO Box 54, Wairoa 4160, Hawke's Bay

🏠 Coronation Square, Queen Street, Wairoa

INFORMATION SHEET 20

Earthquake Protection - Seismic Restraints

Inbuilt and free-standing fireplaces must be secured to prevent seismic movement (earthquake). To achieve this your fireplace must be securely fixed to the structure of the building, this is usually completed by bolting/fixing through the hearth and into the flooring. Specific manufacturing fixing requirements must be adhered to, where applicable.

The hot water cylinder represents a large inertial mass – a 135 litre cylinder weighs approximately 170kg when full. Without restraint, earthquakes can cause hot water cylinders and header water tanks to rock and move, cracking pipes and causing expensive and messy water damage. In large earthquakes, cylinders may slide making hot water a hazard, or topple over creating an obstruction in an exit path.

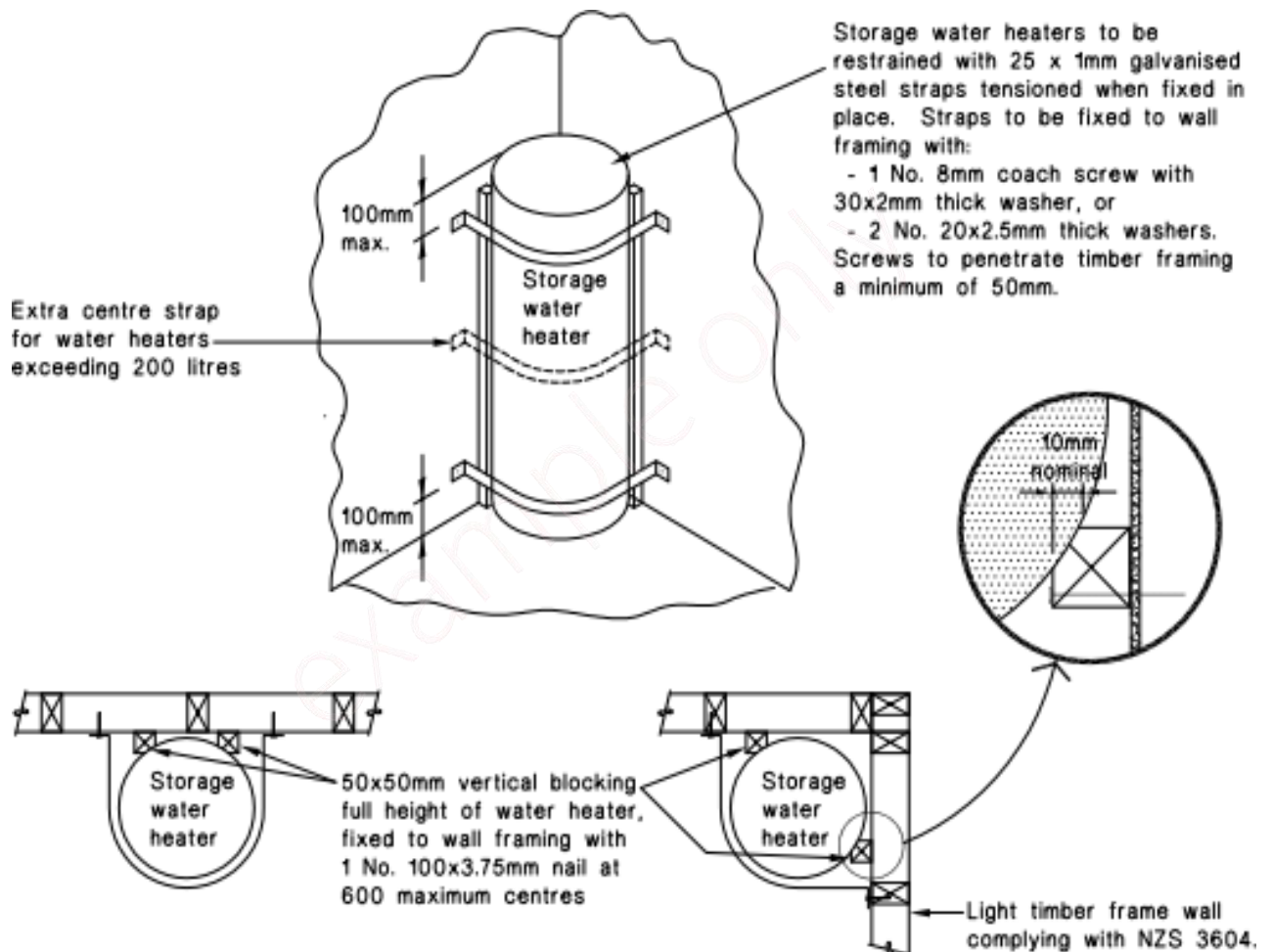



WAIROA DISTRICT COUNCIL

☎ +64 6 838 7309

☎ +64 6 838 8874

✉ consents@wairoadc.govt.nz

🌐 www.wairoadc.govt.nz

📮 PO Box 54, Wairoa 4160, Hawke's Bay

🏠 Coronation Square, Queen Street, Wairoa

INFORMATION SHEET 20

FINAL STEPS

INBUILT FIREPLACES

Once the Building Consent has been granted and issued, you will need to arrange an inspection after the existing fireplace has been removed and BEFORE the new fireplace is installed.

The Building Officer will check that the chimney and fireplace are structurally sound and suitable for the new fireplace, and that any gaps or holes in the fireplace have been adequately sealed.

The existing hearth is sound, and that the width meets the fireplace manufacturer's specifications.

If the current fireplace and chimney are constructed of masonry (brickwork) then the Building Officer will check its double thickness, unless otherwise specified by the manufacturer.

A second and final inspection will be required after the fireplace is installed.

The fireplace must not be used until you have applied for and received your Code Compliance Certificate.

FREE STANDING FIREPLACES

Once the Building Consent has been granted and issued, and the fireplace is installed, you will need to arrange an inspection of the new fireplace to ensure compliance with the manufacturer's specifications and the approved plans.

This inspection MUST happen prior to the fireplace being used. The fireplace must not be used until you have applied for and received your Code Compliance Certificate.



WAIROA DISTRICT COUNCIL

☎ +64 6 838 7309

☎ +64 6 838 8874

✉ consents@wairoadc.govt.nz

🌐 www.wairoadc.govt.nz

📮 PO Box 54, Wairoa 4160, Hawke's Bay

🏠 Coronation Square, Queen Street, Wairoa

INFORMATION SHEET 20

DOCUMENT/ INFORMATION GUIDANCE

Code Compliance Certificate

Your final step is applying for a Code Compliance Certificate. This is an application form which can be downloaded from the WDC website or can be obtained at the Council offices.

When the final installation has been passed, you must complete an application for a Code Compliance Certificate.

On receiving your signed Application for Code Compliance Certificate, Council will issue your Code Compliance Certificate

<https://www.wairoadc.govt.nz/assets/Document-Library/Forms/Building/Application-For-Code-Compliance-Certificate-new.pdf>

Top Tips:

- Always follow the manufacturer's recommendations for installation and usage. Ask for assistance if there are any points you are unsure of.
- The manufacturers specified clearances for framing timber and combustible materials must be adhered to.
- Only use the fuel for which the appliance was designed.
- Regularly clean all freestanding and inbuilt heating appliances, including flue pipes and chimneys, and check for soundness.
- All heaters, both inbuilt and free-standing, must be secured to prevent movement during an earthquake
- Emission standards must be adhered to.
- Fire Box must be an authorised burner with a registered Ecan number.

For further information on Fireplaces, please contact the Building Department on 06 838 7309.